

MEMS Control Moment Gyroscope Design and Wafer-Based Spacecraft Chassis Study

Joel Reiter^a, Karl Böhringer^a and Mark Campbell^b

^aUniversity of Washington, Dept. of Electrical Engineering
Box 352500, Seattle, WA, 98195-2500

^bUniversity of Washington, Dept. of Aeronautics and Astronautics
Box 352400, Seattle, WA, 98195-2400

ABSTRACT

Satellites based on microelectromechanical system (MEMS) technology and tailored to low-cost space missions are investigated to determine their characteristics and feasibility. This work explores an alternative chassis formed from a stack of microfabricated silicon wafers. The outer layers contain optical sensing, micropropulsion and power generation systems whereas internal layers contain computers, RF components and mechanical sensors. This technique has the advantage of saving space and weight while allowing for easy design changes and precise tailoring to mission specifications.

This concept is expanded through a design study of the MEMS control moment gyroscope which is used in satellite attitude control. In addition, a feasibility study is performed with special regard to the alternative chassis outlined above.

This work (part of a Phase I NASA Institute for Advanced Concepts study) demonstrates that a wide variety of spacecraft components can be fabricated with silicon processing techniques. This approach may lead to batch-fabricated, high-volume, low cost, redundant teams of MEMS spacecraft.

Keywords: MEMS, pico-satellite, multi-wafer, integrated microsystem, low-cost space mission

1. INTRODUCTION

In response to a changing set of attitudes in the aerospace community, MEMS spacecraft subsystem technology is quickly finding a central role. These devices have the potential to fulfill the same mission as their full sized counterparts while using dramatically less power, volume and mass. Times have clearly changed from thirty years ago when the budgets available to space programs were much larger than those available now. At that time there existed sufficient resources to support the launch of huge, highly redundant, monolithic spacecraft after a long development period. As budgets continue to shrink and public interest becomes less focused the concept of: “lighter, faster and cheaper” now rules the day. In this climate MEMS based spacecraft subsystems are becoming increasingly pivotal. One unique possible MEMS response is the prototyping of many different device variants on a single, lightweight wafer. This wafer is subsequently tested in orbit and the best performing versions are selected for further development. This type of batch testing is clearly impractical for large, conventional avionics packages.

As a complete set of MEMS spacecraft components (sensors, actuators and scientific packages) become available, entire spacecraft made up almost exclusively of MEMS devices, using various wafers types as a chassis, are envisioned. These integrated satellites would be rugged, mass produced items that could be launched in groups with almost a “fire and forget” attitude. This paper examines the concept of a fully integrated satellite and proposes a new type of MEMS spacecraft subsystem, the control moment gyroscope.

A related program at the University of Washington hopes to take advantage of the novel traits for MEMS spacecraft outlined above in the production of an Intelligent Satellite Team (IST). Studies are underway to determine

Joel Reiter: joelr@ee.washington.edu

Karl Böhringer: karl@ee.washington.edu

Mark Campbell: mcamp@aa.washington.edu

how multiple satellites can co-operate and collaborate to improve mission reliability, enable new types of measurements to be obtained and reduce the costs of doing science in space. Their current focus is on flying micro-satellites in formation (both in Earth orbit and beyond), incorporating Artificial Intelligence and mission planning into the satellites and developing missions tailored to the IST concept.¹

In this paper a design for a control moment gyroscope is proposed which may avoid typical, inertial scaling disadvantages. In addition, a satellite containing this element and built from atypical materials is illustrated.

2. CONTROL MOMENT GYROSCOPE

MEMS provide a number of techniques for changing the orientation of a microsatellite. Most recently there has been a flurry of interest in the use of microthrusters.^{2,3} These devices are quite rugged, low power and are easily extended to bulk fabrication. One problem these exclusively chemical thrusters share is that they will eventually expend their fuel. This must coincide with the end of the satellites mission, or at least with the end of the portion that requires attitude adjustments. Momentum devices, such as the control moment gyroscope (CMG), can overcome this fuel problem because they are electrically actuated. If run off the power from solar arrays their fuel “supply” is nearly inexhaustible. In the past these devices have seen less investigation due to the perceived poor scaling laws associated with them. In the execution of this study it has been determined that there are practical methods to mitigate this problem through the use of devices working in parallel and a systems approach to device scaling.

2.1. Use of the Coriolis Force

The operating principle of the CMG is similar, yet precisely opposite, to that of a normal gyroscope. The CMG uses the Coriolis force to influence the outside world as opposed to measuring the Coriolis force exerted upon it. In a classic gyroscope a spinning or vibrating proof mass is influenced by an outside torque. This in turn produces a force that is the cross product of the two; the Coriolis force. When measured, this force indicates the angular rate of change of the system. A schematic view of these forces can be seen in Fig. 1.

In this situation imagine a disk floating in space, initially aligned with the axes in Fig. 1. The disk is rotating at an angular velocity of ω and has inertia I , thus the angular momentum of the disk is $L = I\omega$, pointing along the x-axis. An external torque τ_Ω , aligned with the y-axis, acts on the system producing the angular velocity Ω . This change in direction of L results in the torque τ_r , which for a brief moment is aligned with the z-axis. This system, simplified to the disk described above, can be represented as

$$\tau_r = L \times \Omega \tag{1}$$

$$L = I\omega = \frac{MR^2}{2}\omega \tag{2}$$

where the variables are defined as above and M is the mass of the disk and R is the radius. As can be seen from (2) it is advantageous to maximize M and ω in an effort to produce a high performance CMG. Taken together, these variables do not inspire confidence in the scaling of this device. Rotating structures, when constructed of polysilicon to form electrostatic motors, typically have high rotational friction, high driving voltages, low mass and low survival time.⁴ In an effort to minimize these issues the CMG described here relies on in phase angular displacement as opposed to continuous rotation.

2.2. Initial Modeling

The simple implementation outlined in Fig. 1 suffers from numerous problems upon actual implementation using MEMS technology. The foremost of these is maintaining a rotating structure. With current electrostatic rotary devices the required longevity or speed is unlikely to be obtained. To solve this problem a CMG is designed to use periodic motions rather than continuous rotation. As a consequence the vectors found in Fig. 1 are replaced by their periodic analogs.

$$\Theta(t) = \Theta_o \sin(2\pi ft) \tag{3}$$

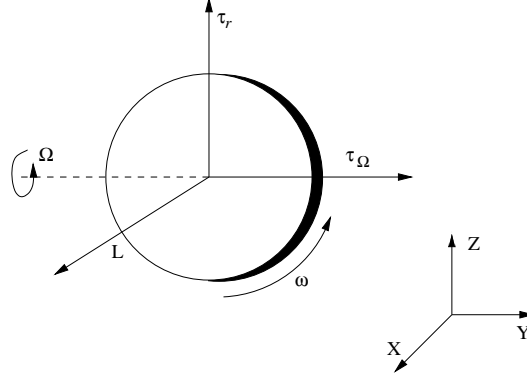

Figure 1. Vector and object representation of Coriolis force

$$\Psi(t) = \Psi_o \sin(2\pi ft) \quad (4)$$

These equations presume that the rotation frequency of the disk is the same as the frequency that the plates pitches in and out of the plane, thus, both values are written as f . Reflecting the periodic nature of this system the maximum angle that the disk can pitch is Θ_o and the maximum angle it can rotate is Ψ_o . These equations are transformed to exchange the positional equations listed in (3) and (4) for velocity.

$$\Omega(t) = \dot{\Theta}(t) = \Theta_o 2\pi f \cos(2\pi ft) \quad (5)$$

$$\omega(t) = \dot{\Psi}(t) = \Psi_o 2\pi f \cos(2\pi ft) \quad (6)$$

Substituting these values into (1) while noticing that the vectors are at right angles to each other produces the equation

$$\tau_r = I\Omega(t)\omega(t) = I(\Theta_o 2\pi f \cos(2\pi ft))(\Psi_o 2\pi f \cos(2\pi ft)) \quad (7)$$

which after collecting terms is equal to

$$\tau_r = I(2\pi f)^2 \Theta_o \Psi_o \cos^2(2\pi ft) \geq 0 \quad (8)$$

where I is the moment of inertia of the rotating structure. Thus, with the final result of (8) the resultant torque is shown to be dependent on the moment of inertia of the rotating plate, the frequency at which the structures move and the maximum deflections of the rotational and pitching elements. The only restriction is that these movements occur in phase and at the same frequency. Since this is controlled by external driving signals either condition should not be difficult to maintain. From (7) it is easy to determine that a 180 degree phase shift in either (3) or (4) will result in a τ_r that is always less than zero. In the result shown in (8) all the motions are in phase and the average, resultant torque is always greater than zero.

The question arises that even though there is a non-zero torque produced, can realistic objects be manipulated. If seen without a frame of reference the torque produced by the CMG seems to scale with size quite poorly. In fact, as the linear dimensions of the CMG are reduced, the resulting torque scales, albeit roughly, to the fifth power. However, this analysis presumes that the satellite changes size, while the CMG inside it retains the same moment of inertia. In the real world this is not the most likely scenario. What is more likely is that the satellite is scaled as the CMG is scaled, thus, the moments of inertia for both devices are effected at the same rate and the system, seen as a whole, becomes scale-independent. Although not as elegant a way to alleviate scaling effects, the potential also exists for operating the CMG in massively parallel structures. This option carries with it the necessity of balancing the production of more torque versus the increase in power consumption, mass and volume.

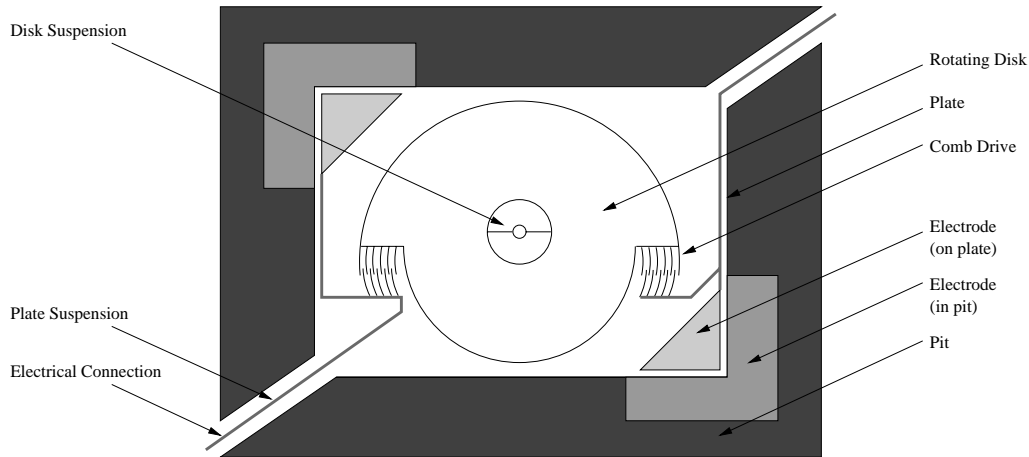

Figure 2. Proposed CMG design (top view, not quite to scale)

2.3. Proposed Design

One possible design for the CMG is shown in Fig. 2. In this design the rotational section is placed on a suspended silicon platform placed above a pit that has been etched completely through the wafer. The wafer supporting the platform is subsequently bonded to a Pyrex carrier.⁵ The actuation of the platform is performed through electrostatics between the electrodes on the corners of the platform and the electrodes on the surface of the Pyrex carrier. This type of actuation and the resonances associated with the suspension arms has been well modeled in the literature.⁶ Specific sizing will trade off the resonance frequency of the suspension against the desired frequency of operation and the minimization of the actuation voltage. These problems are currently being addressed in preparation for fabrication.

The rotation of the disk is controlled by the comb drives at its perimeter. On the figure only two comb drives are shown, but, this number could be expanded until the disk is maximally occupied. Using a disk diameter of $150\ \mu\text{m}$ as an example, rotations up to 10 degrees, corresponding to a pull in of $13\ \mu\text{m}$, are seen as realistic.

Shown in Fig 2, the stationary fingers of the comb drives are electrically connected to the movable electrodes of the platform. To synchronize the device, non-overlapping, opposite phase square waves are fed to the comb electrodes. The amplitude of these waveforms should produce maximum rotation of the plate at a frequency below the resonance frequency of the central suspension structure of the disk and the suspension structure of the platform. With the voltages of the comb drive and movable plate electrodes determined, the electrodes on the Pyrex carrier are energized with a similar square wave. The amplitude of the signals on the non-moving plate electrodes are such that the platform reaches its maximum deflection at the rising and falling edges of the square wave actuating the comb drives. This purposed waveform is shown in Fig. 3. Since there is only one oscillating frequency driving the system, the movable elements naturally fall into the motion described in (8). Using the rough sizing approximations show in Table 1 initial calculations indicate torques in the neighborhood of $2.3 \times 10^{-12}\ \text{Nm}$ are feasible from a single device. Application of this level of torque to a solid sphere of silicon, 0.5cm in diameter, results in an acceleration of approximately $3.75 \times 10^{-5}\ \text{rad/sec}^2$. This torque is clearly too small for radical angular changes involving larger spacecraft; however, for precision pointing adjustments this fine a level of control is desirable.

This proposed structure will under go extensive simulation and testing, culminating in its construction. After characterization in vacuum and in low friction situations, such as on an air table, it will be included in the University of Washington microsatellite for space qualification. In this role it will act as a backup system to the micro-Pulsed Plasma Thrusters under development by the University of Washington and Primex Aerospace (Redmond, Washington).

3. SILICON WAFER BASED SATELLITES

Current spacecraft design starts with a chassis to which components are subsequently bolted. In the last decade these devices have moved from aluminum to more exotic composites and metals.⁷ However, with the application of

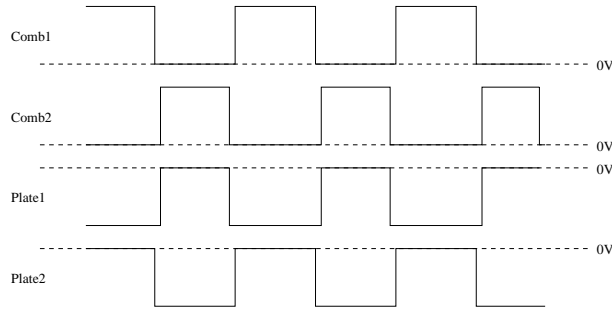

Figure 3. Proposed CMG driving waveforms

Table 1. Example sizing data for Control Moment Gyroscope

rotation angle (Ψ_o)	10°
pitch angle (Θ_o)	3.5°
frequency (f)	1 kHz
plate radius	$150 \mu\text{m}$
plate height	$2 \mu\text{m}$
plate density	3.44 g/cm^3

MEMS technologies the chassis could be dispensed with altogether in production of a satellite made from silicon wafers and other substrates.

Fig. 4 illustrates the potential design of a wafer based satellite. The exterior layers include devices that absolutely must be exposed. These include micro-thrusters,^{2,3} solar cells and optical sensors and communication links. The interior wafers are composed of microelectronics, non-optical sensors such as magnetometers and batteries. All of these layers connect to each other using through wafer vias.⁸ In Fig. 4 the layers are shown offset from one another for illustrative purposes. In the actual device the edges would be aligned.

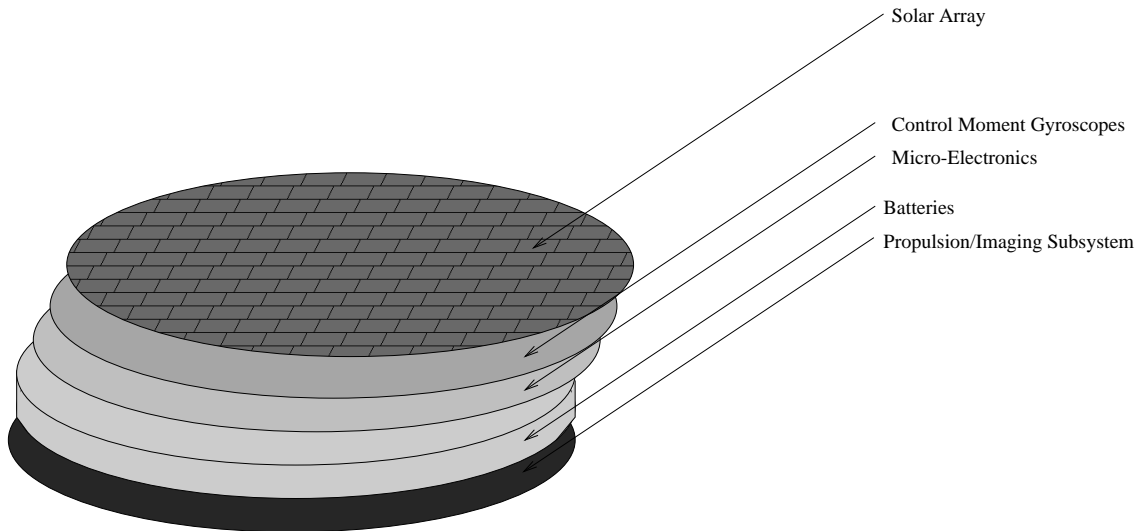

Figure 4. Silicon Wafer Based Spacecraft

Clearly, some MEMS processes are not completely compatible with each other and if large areas are unoccupied, the cost of high quality wafers is inefficiently utilized. To integrate these systems together multiple layers of metal can be patterned onto an inexpensive substrate, the devices bonded to it and then electrically connected using solder bumps or conventional wirebonding. For devices that include out of plane motion there exists some difficulty in attaching another substrate directly above it. This problem can be eliminated by creating concave regions on the back of the upper wafer or including spacers between the two wafers. In many cases, the amount of out of plane motion can be a significant fraction of the wafers thickness so this extra space would need to be allocated.

For a device like the CMG this kind of space would be necessary to handle its out of plane motion. This extra fabrication issue would be acceptable when the benefits of including the device are weighed as a whole. The CMG, more likely many in parallel, would provide the satellite with a simple, low power method to do extremely accurate pointing. This resource could continue indefinitely if the devices were powered using solar electricity because fuel would be practically inexhaustible. Layout is simplified since the CMG can generate torque in two opposite directions. This means the satellite can be rotated to any orientation while using only two set of CMGs placed in the same plane and orthogonal to each other. Finally since the CMG is imparting torque to the satellite its position relative to the center of mass is unimportant as long as the structure is suitably stiff.

A system, put together with CMGs and other MEMS components, opens up a number of novel avenues when designing space missions, most of which focus on reduced cost and the potential for mass produced satellites. In this case, redundancy will go beyond that of major spacecraft subsystems to now provide entirely redundant spacecraft. This allows for riskier mission profiles and the faster adoption of new technologies. It also enables the production of meaningful satellite "swarms" without incurring huge expense. These large groups of satellites, possibly numbering in the thousands, can be used to make novel, distributed measurements or to test out and apply theories concerning large systems and co-operative behavior.

The benefits of this type of spacecraft have further advantages unrelated to unit cost. This spacecraft has the potential for being extremely robust which allows the consideration of otherwise impractical launch mechanisms, such as mass drivers. Conventional satellites would be destroyed upon accelerating at thousands of gravities, however, what amounts to almost a solid piece of silicon will not have this difficulty. Owing to strength of items such as suspension members and the inherent low mass nature of MEMS an extremely rugged device is produced.⁴ By taking advantage of this launch technique costly booster rockets can be avoided.

4. CONCLUSION

A design for a MEMS control moment gyroscope has been developed which has the potential of producing sufficient torque to modify the attitude of microsatellites. This design will undergo substantial design development and simulation in the near future in anticipation of fabrication and integration into the University of Washington microsatellite. A motivation for a spacecraft design consisting of only silicon and other wafers was also developed along with ideas as to its execution.

5. ACKNOWLEDGMENTS

This work was supported by NASA Institute for Advanced Concepts grant 07600-009.

REFERENCES

1. K. Böhringer and M. Campbell, "Intelligent satellite teams for space systems," in *2nd International Conference on Integrated Micro/Nanotechnology for Space Applications*, (Pasadena, CA), April 1999.
2. D. H. Lewis, Jr., S. W. Janson, R. B. Cohn, and E. K. Antonsson, "Digital micropulsion," in *12th IEEE International Micro Electro Mechanical Systems Conference (MEMS '99)*, January 1999.
3. C. Rossi, D. Esteve, N. Fabre, T. D. Conto, V. Conedera, D. Dilhan, and Y. Guelou, "A new generation of mems based microthrusters for microspacecraft applications." unpublished.
4. B. Stark, "Mems reliability assurance guidelines for space applications," tech. rep., Jet Propulsion Laboratory, January 1999.
5. D. Wood, G. Cooper, J. Burdess, A. Harris, and J. Cruickshank, "A silicon membrane gyroscope with electrostatic actuation and sensing," in *Micromachined Devices and Components*, R. Roop and K. Chau, eds., pp. 74–82, SPIE, October 1995.

6. O. Degani, E. Socher, A. Lipson, T. Leitner, D. J. Setter, S. Kaldor, and Y. Nemirovsky, "Pull-in study of an electrostatic torsion microactuator," *Journal of Microelectromechanical Systems* **7**, pp. 373–379, December 1998.
7. W. Larson and J. Wertz, eds., *Space Mission Analysis and Design*, Microcosm, 1992.
8. S. Bouwstra, "Stacked multi-chip-module technology for high performance intelligent transducers," in *Micromachined Devices and Components II*, R. Roop and K. Chau, eds., pp. 49–52, SPIE, October 1996.